

TEST REPORT

N° G-18.078

REPORT DATE: 03/05/2018

YOUR REF.: SPECI-BOX IV PLUS

SUBJECT: Drop tests on combination packagings for land and sea transports required by P650 (ADR/RID/ADN/IMDG).

BY ORDER OF: **CIBESMED S.A.R.L.**
CHE DU CROSET 9B
CH - 1024 ECUBLENS

The results of this report are exclusively related to the submitted and tested items. This report shall not be reproduced except in full without written approval of IBE-BVI.

Recognition:



Stefaan De Ryck
Analyst - consultant
(F)IBC & Dangerous goods
packagings



Eng. D. De Valck
Head of Department
(F)IBC & Dangerous goods
packagings

1. Received samples:

Contact person : Adriano Silauri
E-mail contact person : asi@cibesmed.com

Receiving date of the samples: 14/03/2018

Description of the received samples:

- 5 empty fibreboard boxes.
- 5 complete sets of inner contents.

The samples were sent by Cibesmed to IBE BVI

Testing date: 12/04/2018

Analyst: Stefaan De Ryck

2. Objective of the project:

Tests on packages conform the description of P650 in order to prove their capability to meet the requirements.

All testings with (Q) are executed under the Belac accreditation.

This report is a test report and exclusively refers to the tested objects.

3. Description of the packaging:

Complete packaging for the transport of liquid biological substance, Class 6, Division 6.2 category B.

Composition:

Outer packaging:

Fibreboard box.

- | | |
|---------------------------------|--|
| - Type: | Folding box (see plan & pictures). |
| - Way of closing | Glue strip. |
| - Outer dimensions (L x W x H): | 234 x 123 x 93 mm |
| - Empty weight: | 86 g |
| - Composition: | E-flute
140TLW / 90WS / 120TLB |
| - Reference: | CP066_SP |
| - Supplier: | Dinkhouser Kartonage
Josef Dinkhauser Strasse 1
A - 6060 Hall In Tirol |

Secondary packaging:

Leak-proof plastic seal bag.

- | | |
|-----------------------------|---|
| - Way of closing | Glue strip. |
| - Outer dimensions (L x W): | 275 x 175 mm |
| - Empty weight: | 18 g. |
| - Film thickness: | 155 µm (measured by BVI). |
| - Reference: | KPA-95kPaA5
Specimen bag Cibesmed 148 x 210 mm |
| - Producer: | Vonco Products Inc.
See annex for test report. |

Primary receptacles:

2 inner receptacles: 1 plastic 100ml jar + 2 plastic test tubes, all with liquid content.

Plastic 100ml jar:

- Type: Plastic jar.
- Way of closing: Plastic screw cap.
- Outer dimensions (H x Ø): 72 x 62 mm.
- Volume: 100 ml.
- Empty weight: 13 g
- Reference: 25035
Container 120 ml red cap.
- Amount used for tests: 1.
- Gross weight test sample: 115 g.
Filled by BVI for 98% brimfull capacity
with anti-freeze solution (density
1.1kg/l.).

Plastic test tube:

- Type: Plastic test tubes.
- Way of closing: Plastic plug cap.
- Outer dimensions (H x Ø): 106 x 17 mm.
- Volume: 9 ml.
- Empty weight: 9.3 g
- Reference: Ref. 44619: Vacuumed 16 x 100 mm
clot activator 9 ml.
Ref. 44019: Vacuumed 16 x 100 mm
K2 EDTA 9 ml
- Amount used for tests: 2 test tubes.
- Gross weight test sample: 2 x 20 g.
Filled by BVI for 98% brimfull capacity
with anti-freeze solution (density
1.1kg/l.).

Absorbing material is added in the secondary packaging.

- Reference of the client: 02-01083CG01
- Description of the client: Absorbent pouch Cibesmed 2 g

Maximum gross weight of the tested packaging: 275 g.

Pictures:

Outer packaging outside not set up:



Outer packaging closed:



Packaging with content:



Content



Plastic 100ml jar:



Plastic test tube



Seal bag:



Content with absorbing material:



4. Test program

Performed tests for fibreboard boxes (4G) prescribed by:

- UN-regulations – part 6
- IMDG – part 6
- ICAO-TI – part 6
- ADR – RID – part 6

A. Drop tests (Q):

Filling material	:	Filled & assembled by BVI. The plastic jar and plastic test tubes were filled with an anti-freeze solution with a density of 1.1 kg/l. 1 jar + 2 test tubes were filled.
Number of tested packages	:	1
Preconditioning	:	24h at -18°C
Gross mass of the samples	:	275 g
Drop height	:	1,2 m
Drop orientation	:	First drop: flat on bottom Second drop: flat on top Third drop: flat on the long side Fourth drop: flat on the short side Fifth drop: On a corner

*Note: Absorbing material was not delivered by client.
The primary packagings were wrapped in absorbing paper tissues to simulate the absorbing material.*

Criterion:

No damage liable to affect safety during transport.
No breakage or leakage, nor of the outer, nor of the inner packaging.

Results of the tests:

Flat on the bottom	:	No loss of contents
Flat on the top	:	No loss of contents
Flat on the long side	:	No loss of contents
Flat on the short side	:	No loss of contents
Flat on a corner:	:	No loss of contents

5. Conclusion

The complete packaging is capable to withstand the prescribed tests required by P650 (ADR/RID/ADN/IMDG) and can be used for land and sea transport of infectious substances of Class 6, Division 6.2 category B (UN3373).

The use of other packaging methods or components other than stated in this report will render the use of this package invalid.



Stefaan De Ryck
Analyst - consultant
(F)IBC & Dangerous goods packagings

Verpackungsspezifikation		 Dinkhauser Kartonagen	
Ersteller: JG		Datum: 03.05.2018	
Kunde	Cibesmed Sàrl	Innenmaß	185 x 110 x 83 mm
Produkt	CP086 SP	Material / Qualität	E-Welle weiß/braun, 140TLW / 90WS / 120TLB
Art.Nr. Dinkhauser	<i>folgt bei Produktion</i>	Bedruckung	1-fbg. Flexo
Zg. Nr. Dinkhauser	542386-01		

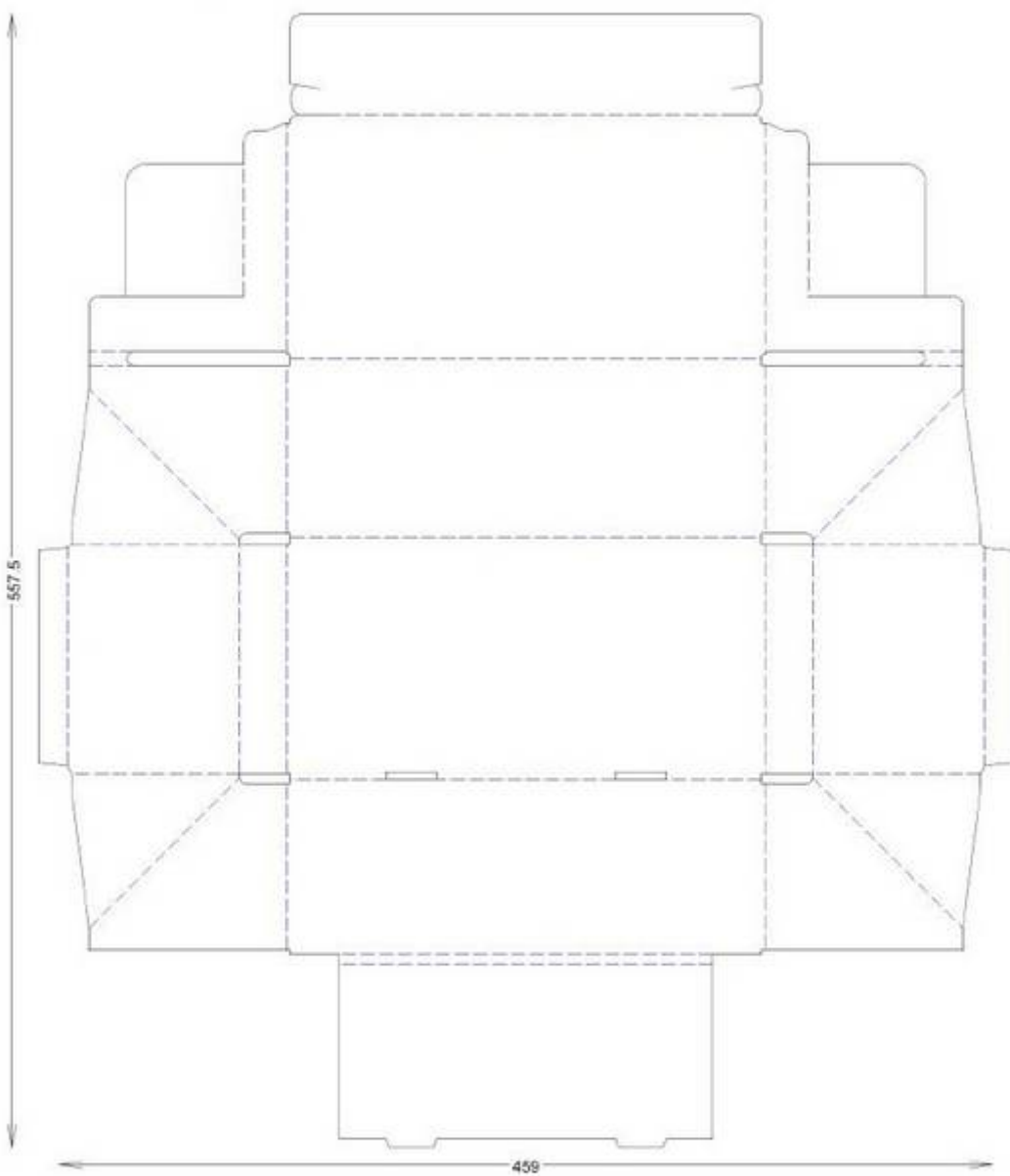

Einzelnutzen

Alle Angaben gelten ausschließlich für den oben genannten Artikel und können materialbedingt abweichen!
Diese Spezifikation unterliegt keinem Änderungsdienst, ist vertraulich und darf ohne Genehmigung weder vervielfältigt, noch an Dritte weitergegeben werden!
Die Verwendung als Produktionsvorlage ist untersagt. Es sind die relevanten Verpackungsnormen (VDW) anzuwenden.

Alle Prozessabläufe bei Dinkhauser Kartonagen sind nach ISO 9001:2008 zertifiziert!
Unsere Packmittelspezifikation soll sie beraten. Die Angaben entsprechen daher unserem besten Wissen. Da die Bedingungen der Verwendung /
Versendung kundenseitig definiert wurde, können für die Eignung und Anwendung der Verpackung keine Ansprüche abgeleitet werden.
Bei Auftragserteilung setzen wir voraus, dass diese Verpackungsspezifikation geprüft und genehmigt wurde.



INTERNAL PRESSURE PERFORMANCE TESTS

Vonco

Vonco Stock 95 kPa 6" x 9" (ID) Bag

TEST REPORT #: 12-1293 (REV 2)

TESTING PERFORMED FOR:

VONCO PRODUCTS, INC.

201 Park Avenue
Lake Villa, IL 60046

ATTN: John La Roi

TESTING PERFORMED BY:

TEN-E PACKAGING SERVICES, INC.

1666 County Road 74
Newport, MN 55055
Phone: 651-459-0671
Fax: 651-459-1430

Issue Date: September 21, 2012
Revision Date: November 5, 2012



Test Report # 12-1293 (REV 2)
Issue Date: September 21, 2012
Revision Date: November 5, 2012
Page 2 of 5

TABLE OF CONTENTS

OBJECTIVE..... 2
 REGULATORY REFERENCES..... 2
 INDUSTRY STANDARD REFERENCES..... 2
 TEST SAMPLE DESCRIPTION 3
 TEST PROCEDURES AND RESULTS – INTERNAL PRESSURE TEST 4
 DISCLAIMER OF WARRANTIES 5

OBJECTIVE

To conduct Pressure Differential Testing on the follow design(s):

- Vonco Stock 95 kPa 6" x 9" (ID) Bag

REGULATORY REFERENCES

Pressure	Title 49 CFR ^① 173.196(a)(6)	Category A Infectious Substance Packaging
Leakproof	Title 49 CFR ^① 173.199(b)(3)	Category B Infectious Substance Packaging
	ICAO ^②	Packing Instructions 620 and 650

^① United States Department of Transportation Code of Federal Regulations (CFR) Title 49, Transportation, Parts 100-185
^② Technical Instructions for the Safe Transport of Dangerous Good by Air (ICAO)

INDUSTRY STANDARD REFERENCES

Pressure	ASTM ^③ D7660:	Standard Guide for Conducting Internal Pressure Tests on United Nations (UN) Packagings
-----------------	--------------------------	---

^③ American Society for Testing and Materials (ASTM)

EQUIPMENT

All inspection, measuring and test equipment that can affect product quality is calibrated and adjusted at prescribed intervals, or prior to use, and is traceable to NIST, using ANSI Z540 as an overall guide for calibration certification.

NOTES

Note for Rev. 2: Report 12-1293 dated September 21, 2012 has been updated on November 5, 2012. This report is being revised to include the Title 49 CFR 173.199(b)(3) regulatory reference per the client's request.

Note for Rev 1: Report 12-1293 dated August 14, 2012 has been updated on September 21, 2012. This report is being revised to change the bag material description. Also, revisions to the test results page were made per the client's request.



Test Report # 12-1293 (REV 2)
Issue Date: September 21, 2012
Revision Date: November 5, 2012
Page 3 of 5

TEST SAMPLE DESCRIPTION

Vonco Stock 95 kPa 6" x 9" (ID) Bag

MATERIAL:	2-Ply Clear Laminated Plastic
OUTSIDE DIMENSIONS:	6-7/8" W x 10-15/16" L
TARE WEIGHT:	17 Grams
MARKINGS:	Specimen Transport Bag BIOHAZARD USDOT/IATA Certified Made In USA Infekta Packaging International Von Seal® Liquid Tight Bag (Pat. No. 6,913,388)

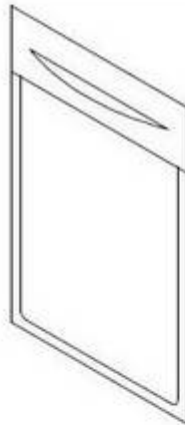

CLOSING INSTRUCTIONS

- Place bag flat on table with the closing tape "UP" and towards yourself.
- Remove the paper liner exposing the adhesive.
- Locate thumbs UNDER the edge of the bag, at the center.
- Using your thumbs, fold over the adhesive at the slit opening (adhesive over adhesive)
- Using your thumbs and starting at the center, press the FOLDED edge firmly working towards the outer edges.
- Starting at the center, firmly press the entire closure area all the way to the outer edges.
- Press the folded CORNERS firmly for a couple seconds.



Test Report # 12-1293 (REV 2)
Issue Date: September 21, 2012
Revision Date: November 5, 2012
Page 4 of 5

TEST PROCEDURES AND RESULTS – INTERNAL PRESSURE TEST

SAMPLE SIZE:

- 3 Bags

TEST DATE:

- August 14, 2012

SAMPLE CONTENTS:

- Tested empty

BAG SEALING METHOD:

- Refer to Closing Instructions on page 3
- After sealing; adhesive was allowed to cure for 30 minutes prior to the start of the internal pressure test

AREA OF PRESSURIZATION:

- Bottom corner of bag

TEST CONDITIONS*:

- 40°F

EQUIPMENT:

- Regulated Air Source
- Dwyer Pressure Gauge; DPG 104 (Gauge #634)
- Thermotron Temp/Humidity Chamber #236

TEST PRESSURE/DURATION:

- 95 kPa (13.8 psi) / 20 Minutes

TEST PROCEDURE (Vonco Products' Protocol*):

- Place the test sample fixtured for pressurization with pressure nozzle and clamp in the 40°F Chamber.
- Apply a 3.0 psi internal pressure to the bag and hold for 2 minutes.
- Slowly increase pressure to 95 kPa (13.8 psi) over a two minute time period. Hold this pressure for a 20-Minute test duration evaluating the sample for rupture/leakage.

INTERNAL PRESSURE TEST RESULTS

TEST SET-UP	Sample	Result	Comments/Observations
	1	Pass	Samples maintained the 95 kPa test pressure for 20 minutes at 40°F with no rupture/leakage.
	2	Pass	
	3	Pass	

CRITERIA FOR PASSING THE TEST

The primary receptacle or secondary packaging must be capable of withstanding, without leakage, an internal pressure producing a pressure differential of not less than 95 kPa.



Test Report # 12-1293 (REV 2)
Issue Date: September 21, 2012
Revision Date: November 5, 2012
Page 5 of 5

DISCLAIMER OF WARRANTIES

TEN-E PACKAGING SERVICES, INC. certifies that the previously described testing services have been performed in accordance with standard good laboratory practices and the Department of Transportation's Title 49 CFR Part 173.196(a)(6) and 173.199(b)(3) and Packing Instructions 620 and 650 of the ICAO Technical Instructions on the Safe Transport of Dangerous Goods by Air. The results included within this test report relate only to the items tested. **ALL OTHER WARRANTIES, EXPRESSED OR IMPLIED, INCLUDING ANY WARRANTY THAT THE PACKAGING TESTED IS MERCHANTABLE OR FIT FOR A PARTICULAR PURPOSE, ARE DISCLAIMED.** In no event shall TEN-E Packaging Services, Inc. liability exceed the total amount paid by **Vonco Products, Inc.** for services rendered.

In the event of future changes to the above referenced test standard, it is the responsibility of **Vonco Products, Inc.** to determine whether additional testing or updating of past testing is necessary to verify that the packaging we have tested remains in compliance with those standards.

Patricia L. Garin
Manager, Technical Services
TEN-E Packaging Services, Inc.
1666 County Road 74
Newport, MN 55055